

34th Annual PURC Conference
New Technologies and
Services in
Telecommunications: Effects
on Competition and Investment

Kathleen Wallman

One Problem Worth Addressing:

- **Universal and Affordable
Broadband Access**

Affordable and Universal Broadband Access

- Bipartisan Support for *Affordable and Universal* Broadband Access
- President Bush has challenged America's broadband providers to provide:
 - **Ubiquitous broadband internet access by the end of 2007**
- Speaker Pelosi's Democratic Innovation Agenda calls for:
 - Invest in a sustained federal research and development initiative that promotes public-private partnerships;
 - **Guarantee affordable access to broadband technology for all Americans within 5 years**

The US is Falling Behind in Global Broadband Competitiveness



Broadband Bargains 2005

Japan followed by Korea leads in "most megabits for the dollar"

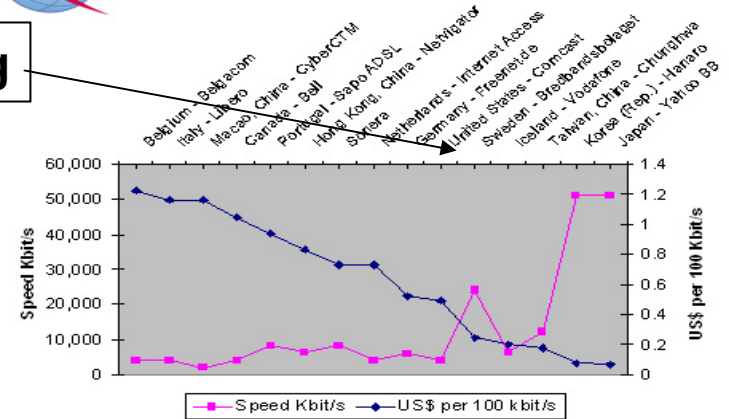
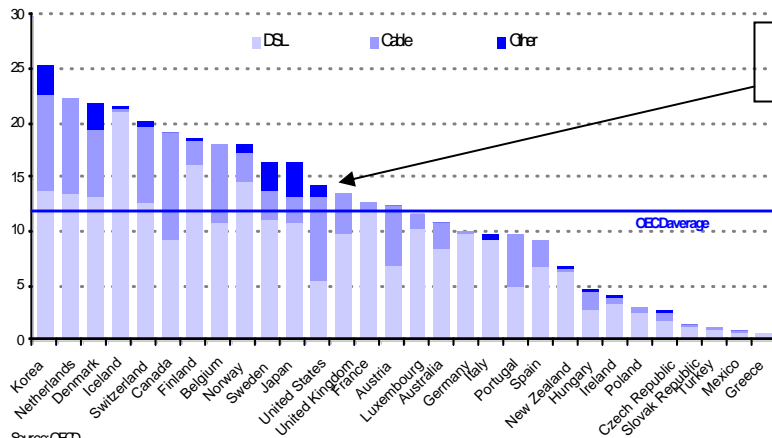

According to ITU Global Rankings, U.S. is 12th in Broadband penetration and have one of the Lowest Value Indicators (Speed to Price Ratios) among industrial nations...

The Picture at Home

– **59% of Low Income American Kids *do not* have Internet Access**

- The Department of Education reports that 59% of children from homes that make less than \$20,000 per year do not have access to the internet. This is nearly 20% more than the national average.
- Minority children are also extremely disadvantaged – 56% of Hispanic and 53% of Black elementary and nursery school students do not have Internet access.

Needed: Third Pipe.

- In 2005 following the Brand X decision, FCC also classified DSL and other LEC broadband services (e.g., FTTH) as information services without any common carriage obligations and unclear non-discrimination regulations which effectively eliminates “non-facilities based competition”
- ISPs and DBS providers are now stranded without competitive bundling opportunities due to inherent conflicts with existing incumbents (i.e., cable and telcos)
- There is a need for an “open national broadband wholesale network” that is an alternative capable of delivering competitive speeds and scalable capacity while using its own facilities (i.e., a “third” data pipe)

The US Broadband market has limited competition leading to high cost to consumers and inconsistent coverage

- US Density and Geography make it difficult to accomplish cost effective and scalable Universal coverage for Broadband using existing technology (both wireline and wireless)
- Large number of users cannot afford existing broadband offerings or have limited to no access, leading municipalities to step in to bridge the gap
- Increasing demands to include broadband as part of an existing Universal Service structure strains the system and imposes undue burden on growth

Case Study: M2Z Networks

- The current technical paradigm in the domestic wireless industry uses paired spectrum so unpaired spectrum has little to no value to incumbents
- M2Z has submitted a license application for **Unpaired and Fallow** spectrum that is without service rules for at least 5 Years
 - 20 MHz Unpaired spectrum between 2155 and 2175
 - No service rules or geographic assignment proposed by FCC
 - Issues related to unpaired spectrum make it infeasible to be used by existing technologies and service providers
 - Immediate Availability

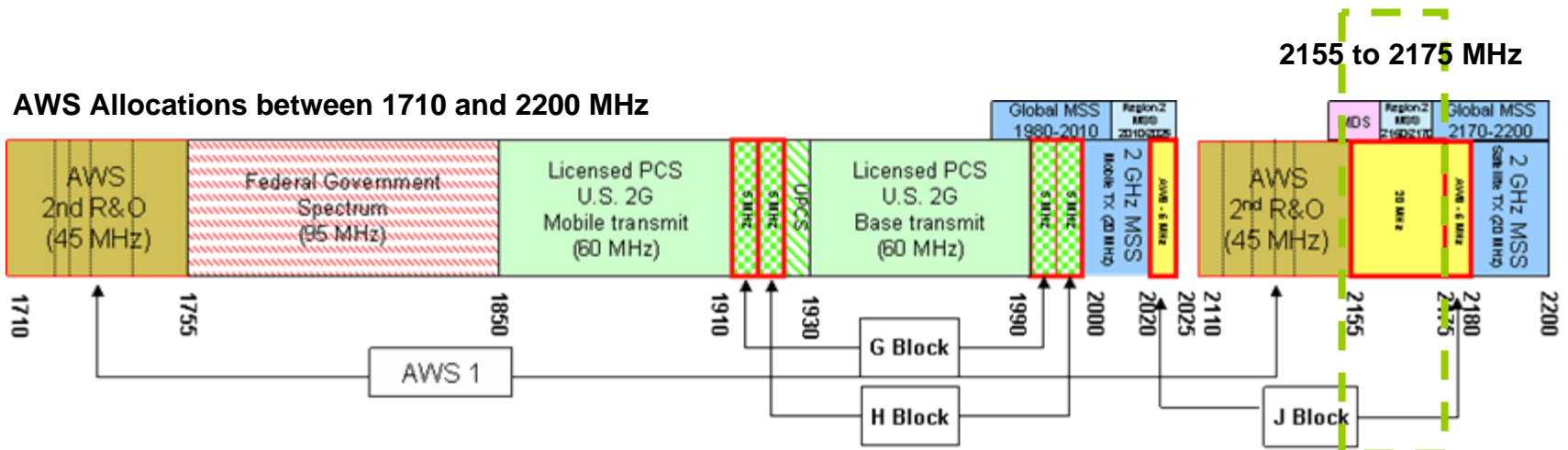

M2Z Proposition: The Ubiquitous Internet

Unlicensed Spectrum
Wireline or Licensed Spectrum

Now

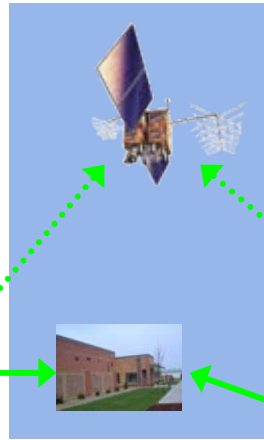

Service Providers

World Wide Web



Future with M2Z

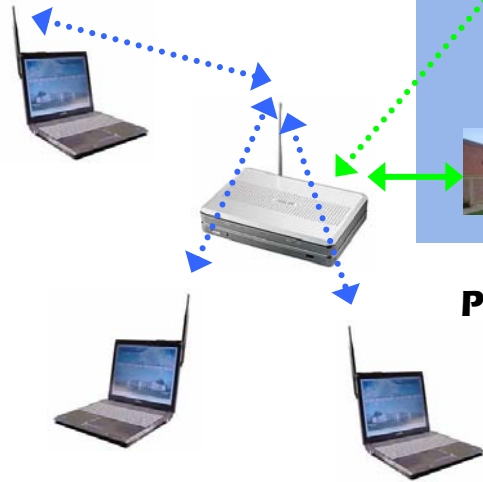

**Unlicensed Spectrum for LANs
... Still need to Access to the Internet
(predominantly wired)**

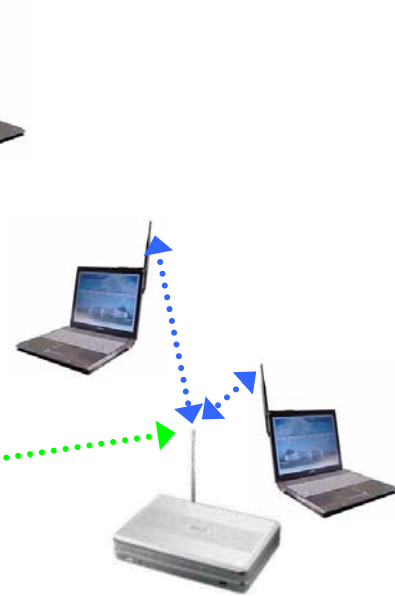

**Unlicensed Spectrum for LANs
... Wireless Access to the Internet
(ubiquitous)**

M2Z Networks: Nationwide Broadband Wireless

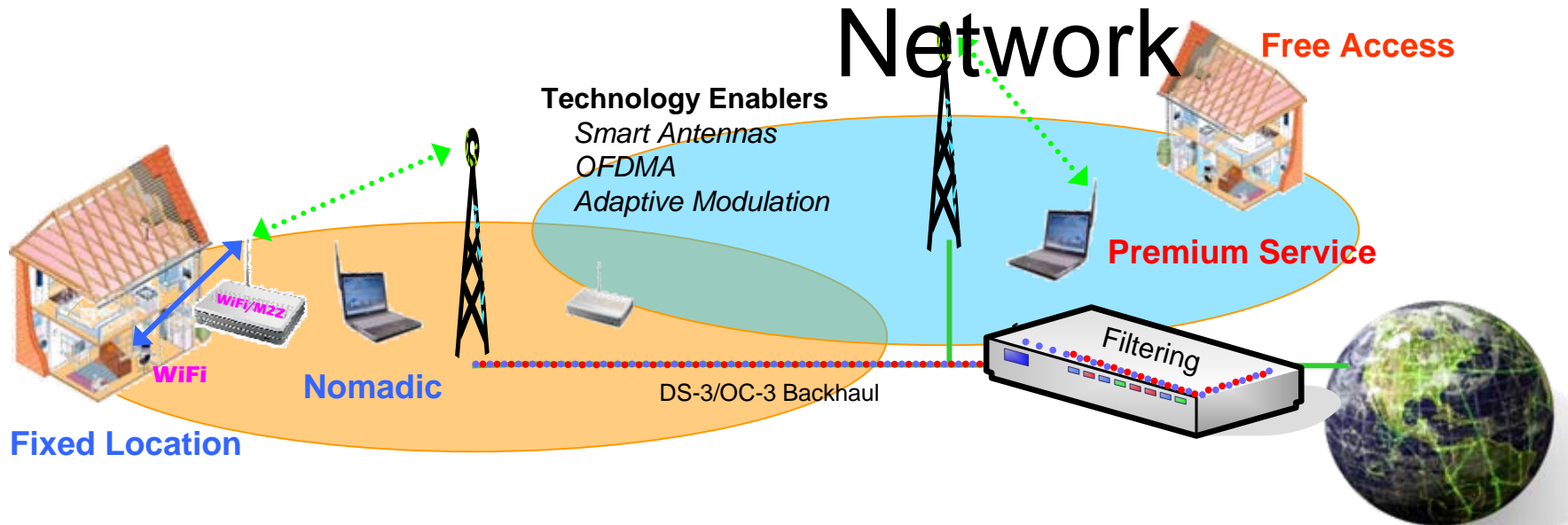

- Fixed and Nomadic Service
- Free Service (up to 384 kbps) at cell edge
- Premium Service (up to 3 Mbps) at cell edge
- Indecent Material Filtering: Mandatory (Free), Optional (Premium)

Smart Antennas and TDD

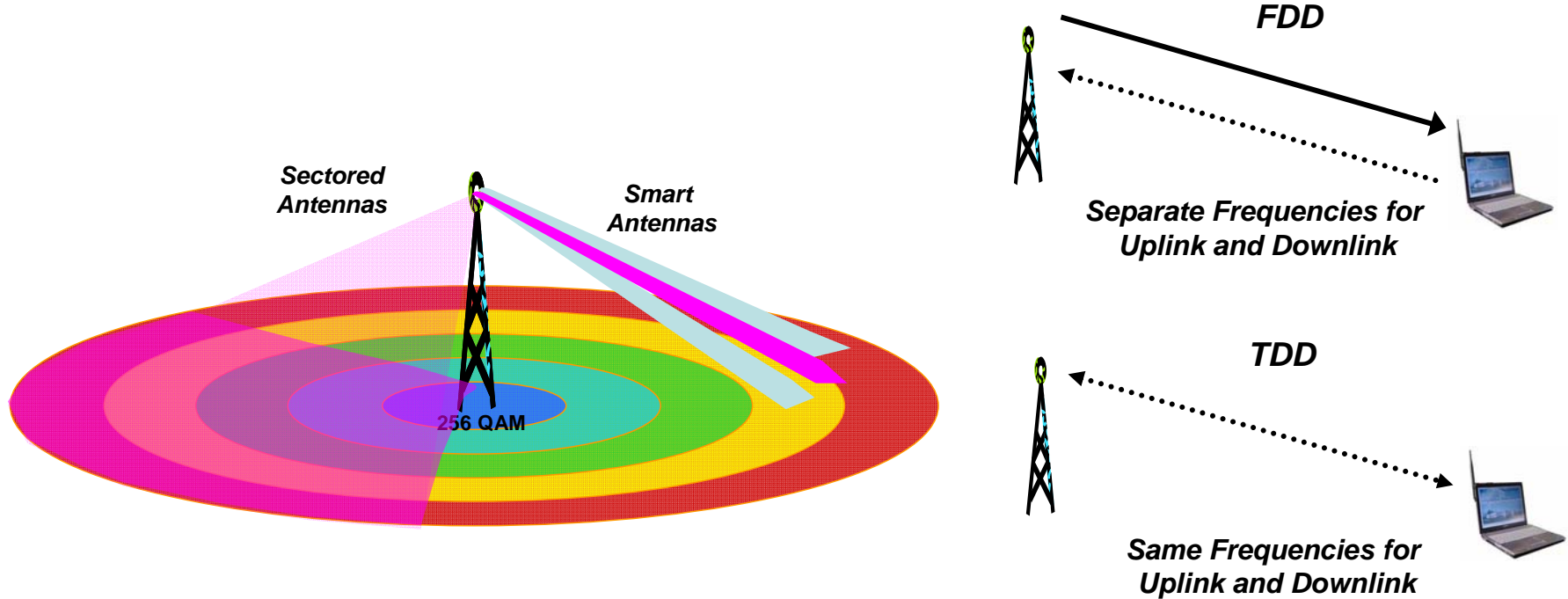

- Smart Antennas and Time Division Duplexing
 - Smart Antennas – increases wireless performance
 - Since TDD uses same frequency for Uplink and Downlink, the antenna can measure the propagation characteristics and adapt.

Challenges for Regulators

- Flexible spectrum allocation policies
 - Contrary to the popular myth, FCC is not required by statute to auction spectrum
- Will they do something innovative finally to solve the access/affordability problem?
- State regulators are generally cordoned off from spectrum policy decisions
 - But state and local governments are being pressured by the realities of the need for access to invest in this space – so state regulators do have a stake.
- Will they give an upstart a chance?
- Role of public-private partnerships

Current Plan for Upper 700 MHz

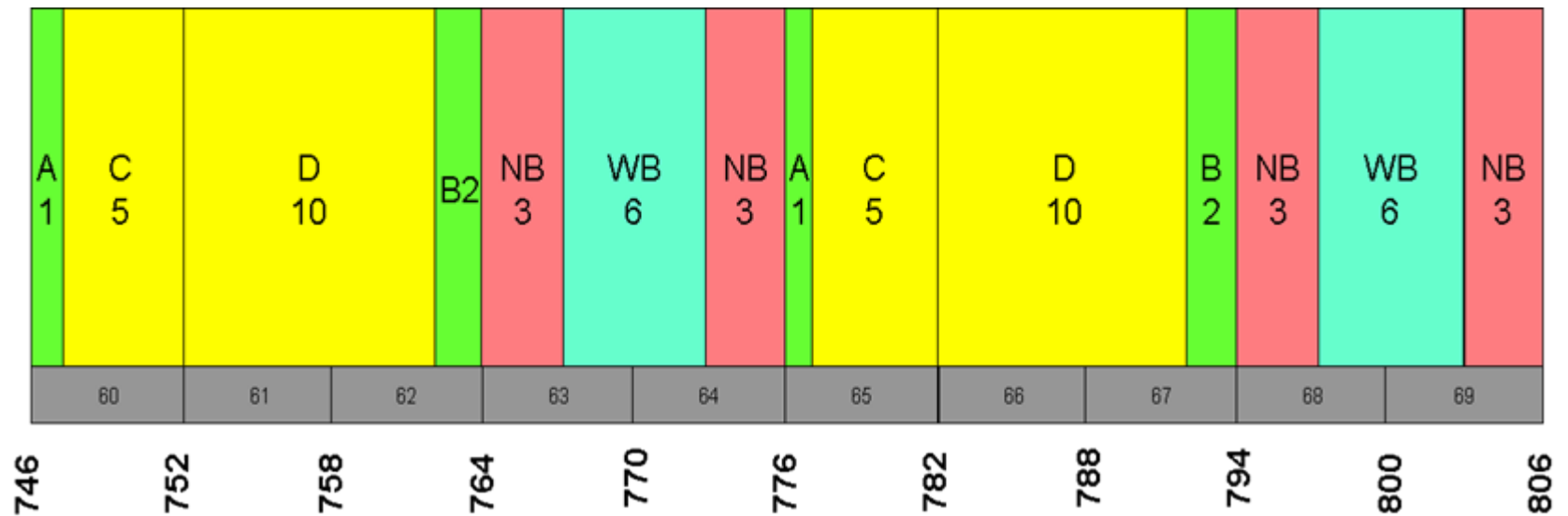

M2Z Free Broadband Service in Competitive Context

M2Z WiMax Search Supported Free Service:

- » **Downstream: 384 kbps**
- » **Upstream: 128 kbps**
- » **Coverage: 95% of US Pop.**
- » **Cost: One time CPE only**
- » **Technology: Standards based**

EV-DO Revision A Service:

- » **Downstream: 400-800 kbps**
- » **Upstream: 300-400 kbps**
- » **Coverage: 40 million subs**
- » **Cost: CPE + \$720/year**
- » **Technology: Proprietary**

How can policymakers help in achieving ubiquitous and affordable access to Broadband?

- Encourage *market based solutions and increased competition*
- *Promote technology neutrality and encourage new technology* in order to overcome the business problems that have kept the current players from achieving broadband ubiquity
- Support market entrants that provide real and substantial consumer welfare enhancing solutions